



Equipment Sales
815 Allgood Road • Marietta, GA 30062
USA
Tel: (770) 422-7230 • Fax (770) 428-7315
www.sstug.com

Parts Sales
TUG Shop: (800) 989-8499 * (770) 422-8021
Fax: (770) 422-8730
www.tugparts.com



Model MX4

Industrial AC Electric Tow Tractor

TUG began offering zero emissions electric powered baggage tractors over twenty years ago. The MX4 AC electric tow tractor represents the latest in TUG's commitment to clean material handling equipment. Not only is the MX4 environmentally friendly, it is also user friendly. The MX4 has been designed with the operator and maintenance technician in mind. Its design provides excellent visibility and ergonomics combined with a low center of gravity, which results in less operator fatigue. The MX4 models feature the Ecostar AC drive system.

Compared to standard DC powered tow tractors, AC drive systems offer the benefits of better electrical efficiency, allowing for longer operation between battery charging and lower maintenance time and cost. Drive motor brushes have been eliminated and the number of electrical contactors sharply reduced. In addition to displaying the conventional battery discharge indicator and hour meter, the dash display of the MX4 serves as a diagnostic tool, allowing the technician to read faults and troubleshoot from the driver's seat. An enclosed cabin, rear inching controls and other options are also available.



Standard features include:

- Recessed headlights
- Back-up lights
- Seat belts
- Power steering
- Split braking systems
- Multiple function dash display with battery discharge indicator, hour meter and fault display
- Four wheel drive suspension
- Package rail

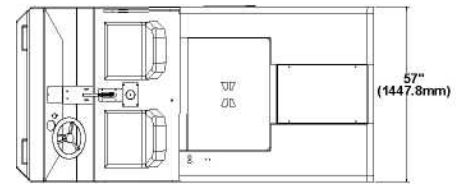
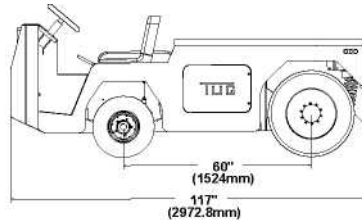
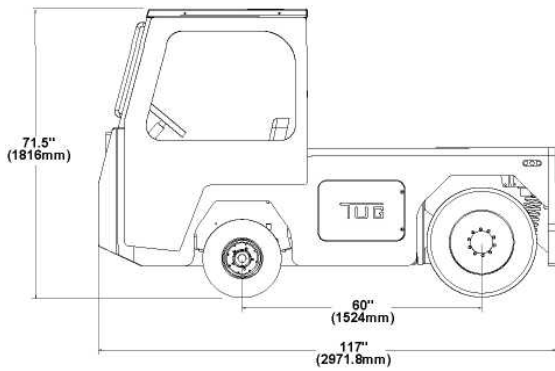

Specifications

Model MX4 AC Industrial Electric Baggage Tow Tractor

Dimensions

Length excluding hitch	117" (2972 mm)
Width	57" (1448 mm)
Height less cab.....	49" (1245 mm)
Height with cab.....	71.5" (1816 mm)
Wheelbase	60" (1524 mm)
Ground clearance	5.5" (140 mm)
Turning radius—Outside	150" (3810 mm)
Inside.....	93" (2362 mm)

Weight and Drawbar

Model GVW (w battery) Drawbar Pull*

MX4-45.... 7400 lb (3364 kg) 4500 lb (2041 kg)

Battery weight is approximately 3500 lb (1591 kg)

* At 0.8 traction coefficient +/- 3% variation on published drawbar pull and weight due to manufacturing tolerances

Speed

Maximum governed speed.....16 mph (25.7 km/h)

Drive System

Type 80 VAC, Integrated motor/axle
 Power Electronics....."Ecostar" 80 V
 System Power (Peak)40 hp (30 kW)
 System Power (Continuous)24 hp (18 kW)

Battery Compartment

Dimensions36" x 26 1/8"
 (914.00 mm x 663.58 mm)

Battery

Powered by (1) 80 V battery
 Battery **Not** included

Brakes

Service Split hydraulic
 Front..... Dry disc brakes
 Rear Wet disc brakes
 Parking..... Wet disc brakes, lever actuated
 Electrical Intelligent, dynamic regenerative braking

Steering System

Orbitrol-operated hydraulic cylinder
 (hydrostatic steering)

Suspension

Rear Coil spring, shock dampened
 Front..... Leaf spring, shock dampened

Tires

Front..... 6 x 9 pneumatic radial
 Rear.....8.0 x 16.5

Brakes

Service Split hydraulic
 Front..... Dry disc brakes
 Rear Wet disc brakes
 Parking..... Wet disc brakes, lever actuated
 Electrical Intelligent, dynamic regenerative braking

Hitch

"E" hitch with extension is standard
 Other options available

Instruments

Battery charge, hour meter and diagnostic faults

Partial Option List

Cab
 Back-up alarm
 Inching controls
 Rubber bumpers
 Programming kit
 Others available upon request



Equipment Sales
 815 Allgood Road • Marietta, GA 30062 USA
 Tel: (770) 422-7230 • Fax (770) 428-7315
 www.tugtech.com

Parts Sales
 TUG Shop: (800) 989-8499 * (770) 422-8021
 Fax: (770) 422-8730
 www.tugparts.com